

Standard configuration

- 180° rotation of the form
- Side to side expanders with antistretch mechanism
- Removable lapel clamp
- Telesoping height up to 150cm
- Electronic programmer

Options

- Pneumatic vent clamps
- 360° rotation of the form
- Side clamps for side seams tensioning
- All-steam iron for touch-up
- Electronic adjustment of blowing strenght

Appliance dimensions and workspace

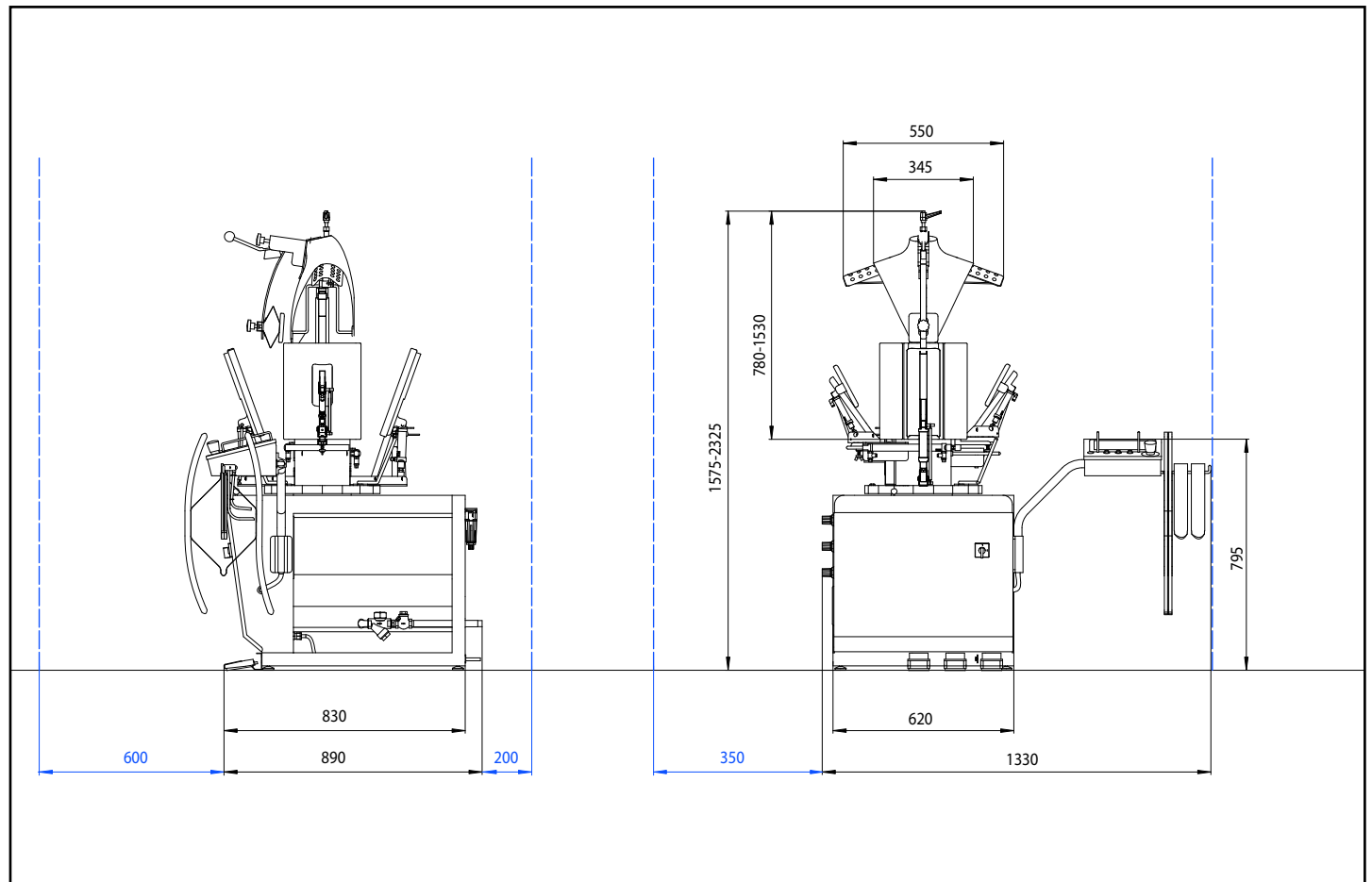

Technical specifications

	5122	5122T226T
Electric requirements	400V 3N AC 50Hz	220V 3 60Hz
Total power	1,1 kW	1,1 kW
Power cable	IEC 60309 H05VV-F, 5 x 1mm ²	IEC 60309 H05VV5-F, 4 x 14AWG
Plug	3P+N+T 400V 3N 10A	3P+T 210-240V 3 16A
Steam inlet	1/2"	1/2"
Condensate outlet	1/2"	1/2"
Compressed air inlet	1/4"	1/4"
Compressed air pressure	600 - 700 kPa	80 PSI
Steam pressure	500 - 600 kPa	80 PSI
Steam consumption	15 - 20 kg/h	33 - 44 lbs/hr
Compressed air consumption	6 NI/min	0.2 cfm
Net weight	160 kg	353 lbs
Ambient temperature	15 - 40 °C	60 - 105 °F

Connections

- A. Power inlet
- B. Compressed air inlet
- C. Steam inlet
- D. Condensate outlet

