

## Standard configuration

- Pneumatic sleeve arms, with short sleeve device
- Tensioning carriage with side and front hem clamps
- Heated front clamp with temperature adjustment
- Front suction
- Powerful hot air blow

## Options

- Insert for rounded cuff
- Touch-up iron
- Water spray group

## Appliance dimensions and workspace

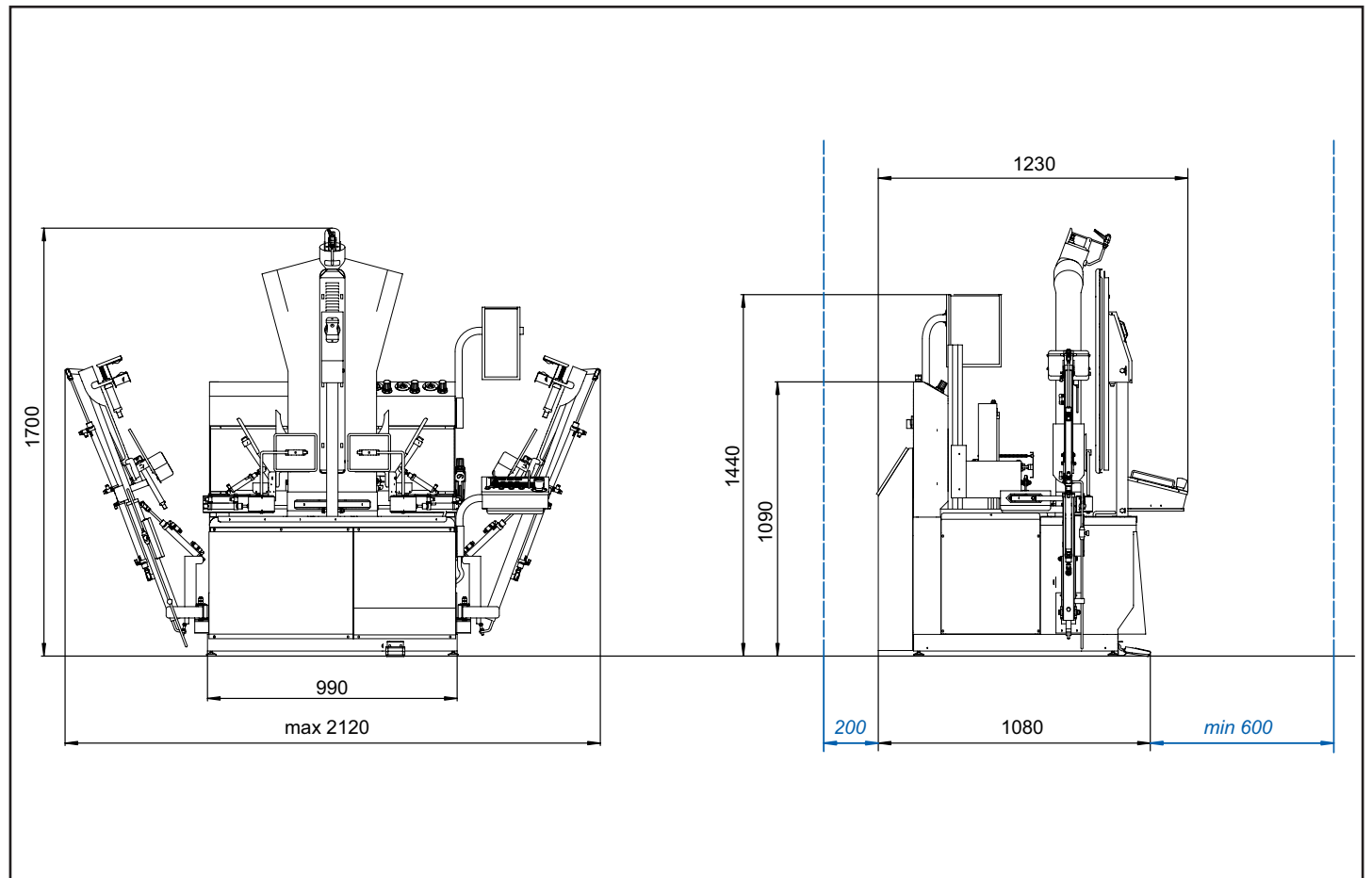

# Technical specifications

	<b>5222</b>	<b>5222T226T</b>
Electric requirements	400V 3N AC 50Hz	220V 3 60Hz
Total power	3700 W	3700 W
Power cable	IEC 60309 H05VV-F, 5 x 1,5mm <sup>2</sup>	IEC 60309 H05VV5-F, 4 x 14AWG
Plug	3P+N+T 400V 3N 16A	3P+T 210-240V 3 25A
Steam inlet	1/2"	1/2"
Condensate outlet	1/2"	1/2"
Compressed air inlet	1/4"	1/4"
Compressed air pressure	600 - 700 kPa	80 PSI
Steam pressure	500 - 600 kPa	80 PSI
Steam consumption	20 - 25 kg/h	45 - 55 lbs/hr
Compressed air consumption	14 NI/min	0.5 cfm
Net weight	300 kg	660 lbs
Ambient temperature	15 - 40 °C	60 - 105 °C

## Connections

- A. Power inlet
- B. Compressed air inlet
- C. Steam inlet
- D. Condensate outlet

