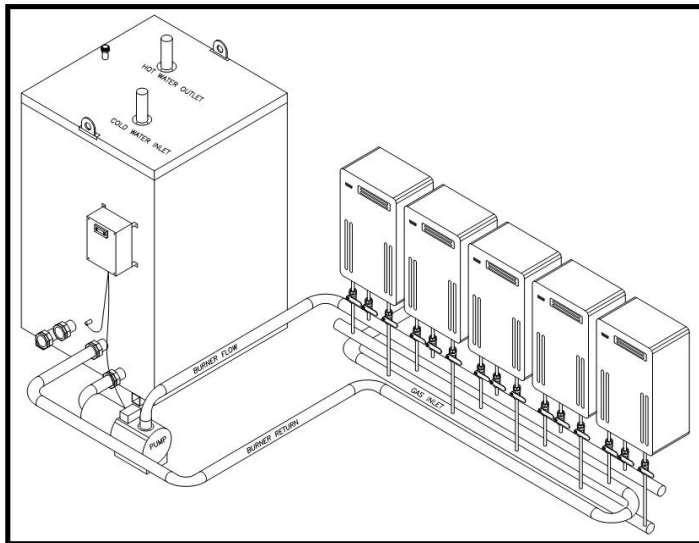

NEW Commercial Continuous Flow Water Heater

Typical Commercial Installation using multiple units
on an Indirect GXC Series Heat Exchanger

TYPE - A mains-pressure, gas, continuous-flow water heater operating with fan-assisted combustion. It is suitable for direct or indirect connections and is approved to Australian Standard AS3498 and AS4552.

HOW IT WORKS - The continuous flow water heater is designed to heat water to a pre determined temperature. This is either when circulated by a pump from a banked system or a storage tank. It can also be used directly from a potable cold water supply.

When used without storage, opening a hot water outlet will activate the flow switch. This causes the gas control to open and go through its firing sequence until a flame is established. The water flows through the heat exchanger and is heated to the temperature nominated. The flame will modulate its intensity depending on the amount of flow through the heater and the incoming temperature to ensure an accurate temperature of $\pm 1^{\circ}\text{C}$.

It can be connected to and used in multiple banked systems or in conjunction with an Edwards SV, GXC or LEX Series depending on the application.

When a pump is employed either as part of a recirculation system or as part of a primary circuit with a storage tank, a call for heat from the pump controller activates the pump that creates the flow through the water heater. The same sequence as above allows the gas valve to "fire up" the burner.

HOW IT WORKS (cont) - The burner heats the water flowing through the heat exchanger that returns back to the banked system or storage tank via the building flow and return loop or primary circuit. This circulation continues until the thermostat set point is achieved or the temperature sensed at the water heater inlet reaches 63°C , whichever is lower. The pump controller then turns the pump off so that the flow stops and the burner shuts down.

HEAT EXCHANGER - Multiple windings of copper tube and fins provide a large heating surface area. It is designed for water supply pressures between 140 – 1000kPa.

CASING – Robust 0.6mm hot dipped zinc coated steel with chromate base and polyester coating.

FLUING - Combustion by products are exhausted by using a fan assisted flue. It is suitable for outdoor installations only in accordance with AS5601.

GAS BURNER EFFICIENCY – The unit has a thermal efficiency of 82% and achieves a 5.2 star energy rating.

HEATER OPERATION IN CIRCULATION LOOPS – The water heater must be set to 75°C when being used in either a flow & return loop or closed circuit loop with an Indirect Heat Exchanger such as the GXC and LEX Series or a Storage Tank such as the SV Series. It is important to note that when used with storage tanks, the water heater will only heat the water to a maximum of 60°C as the firing sequence of the unit is set to shut off at 63°C and come back on at 58°C . When used without a storage tank, the water heater will deliver water at 75°C , but will stop firing when the return water sensed at the inlet reaches 63°C .

SAFETY DEVICES – The unit has FlameSafe™ which is a unique safety feature that provides combustion failure protection should a fault develop.

Built in Self Diagnostic window on the front panel to assist with fault finding and installation

A water pressure relief valve on the unit is set to relieve at 1750kPa to prevent excessive pressure build up damaging the heat exchanger. It automatically resets at 1000kPa.

To prevent water from freezing in cold conditions, anti-frost sensors are incorporated which activate and prevent the unit from freezing.

NOTES:

- The new Continuous Flow water heater can be used in both commercial and domestic applications where circulation (Flow & Return) is needed
- The water heater can be used in conjunction with an indirect heat exchanger such as the GXC & LEX Series or a direct storage tank such as the SV Series.
- Units are suitable for use as Solar Boost. If used without storage tanks, the unit must be set to deliver water not exceeding 60°C. If used with storage tanks, the tank thermostat must be set at no greater than 60°C
- Both Natural Gas & Propane models available

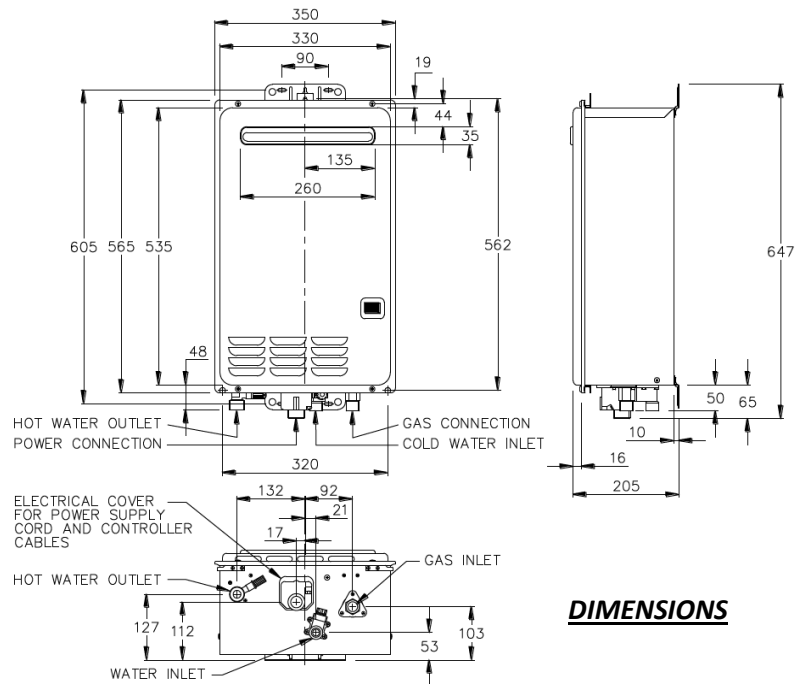

DIMENSIONS

TECHNICAL SPECIFICATIONS

| | Commercial Continuous Flow Model: 871026*F/75C |
|----------------------------------------|------------------------------------------------|
| Maximum Gas Input -MJ/h | 199 |
| Minimum Gas Input – MJ/h | 21 |
| Energy Output - kW | 45 |
| Gas Energy Rating | 5.2 Stars |
| Inlet Pressure - kPa Nat. Gas | 1.13 min. 3.5 max. |
| Inlet Pressure – kPa LPG | 2.75 min. 3.5 max. |
| Water Supply Pressure - kPa | 140 min. 1000 max. |
| Dry Weight - kg | 21 |
| Gas Connection - BSPM | R3/4 / 20 |
| Water Connections - BSPM | R3/4 / 20 |
| Ignition | Electronic |
| Water Temperature Settings – (°C) | 40, 43, 50, 55, 60 & 75 |
| Firing Sequence | 58 to 63 |
| Flow & Return/Circulation Loops – (°C) | 58 to 63 |
| Maximum Flow Rate @ 25°C rise – l/m | 26 |
| Warranty | 5 Years Heat Exchanger, 1 Year Parts & Labour |
| Heater Electrical Supply - V | 240 AC |

(*N = Natural and *P = Propane i.e. model 871026NF/75C)

DISTRIBUTOR:



For more information

Call Sales 1300 132 949 (Australia only)
Call Service 1300 132 948 (Australia only)



Edwards Commercial Hot Water
39 Koornang Road, Scoresby, Victoria 3179
A division of Rheem Australia Pty Ltd ABN 21 098 823 511

Ph 61 (3) 9757 3333 – Fax 61 (3) 9757 3380
website: www.edwards.com.au
email: info@edwards.com.au
ETDS-CFWH-VER1-251108