

TYPE – An indirect, open vented, vertical storage water tank designed to be heated by a remote heat source. It is authorised to Australian Standard AS3498.

HOW IT WORKS – The **LEX Series** is an indirect heat exchange hot or warm water system that is heated by a remote heat source. These include Edwards Heatmate, and HEV series water heaters, as well as the Rheem Continuous Flow water heaters. The water in the storage tank is treated with a tannin-based inhibitor, “Gendex”, which remains in the system during operation and is not consumed. The treated water is circulated through the remote heat source by a pump, and the remote heat source heats the treated water until the thermostat sensor on the storage tank achieves its set-point and switches the circulating pump to the heat source off. The storage tank is open vented to atmosphere, by means of an expansion tank. Located within the storage tank is a copper heat exchanger coil that contains potable, consumable water. As water is drawn through the coil, it is heated by the neutral water.

STORAGE TANK – Is constructed from mild steel designed to withstand high water temperatures of up to 99°C on a continual basis. No anode or artificial lining is required to prevent corrosion. All welding is in accordance with Quality System procedures and standards.

WARM WATER – The LEX range of heaters is approved by NSW Health, in terms of the Public Health Act 1991, for use as Warm Water Generators. Refer to the Edwards Warm Water Manual for information covering installation, commissioning, operating and maintenance.

CENTRAL HEATING – The treated water circuit can also be used for central/process heating applications, up to 400kPa.

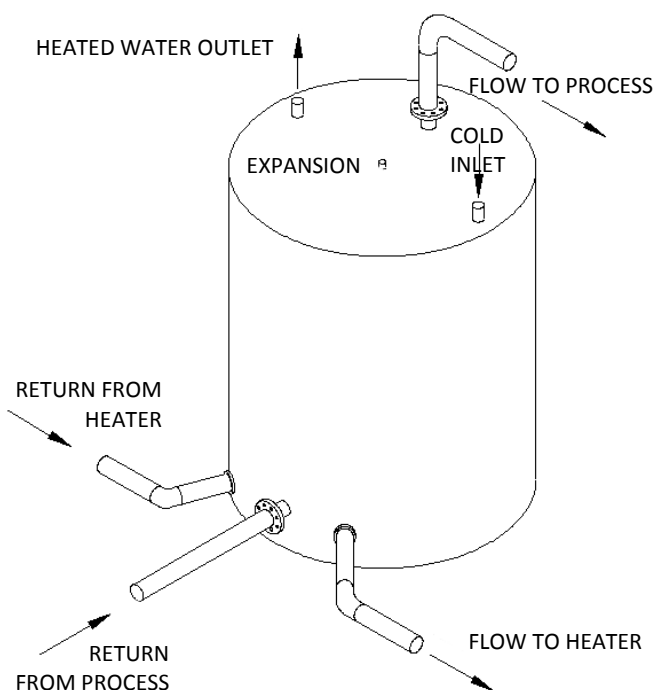

INSULATION – High-density fibreglass encases the storage tank for maximum efficiency.

CASING – Is constructed of durable, Colorbond® for protection against the weather.

SUPPLY WATER QUALITY – Acceptable range:

Refer to the standard warranty conditions available from an Edwards' representative.

FLUING – Any heater connected to the LEX storage tank must comply with Australian Standard AS5601 and any relevant local regulations.

HEAT EXCHANGER – Is constructed of multi-start windings of Ø12.7mm Type B copper tube. Large inlet/outlet headers ensure full mains pressure water flow (Maximum inlet pressure 960kPa, Maximum operating pressure 1200kPa).

CONTROLS – To provide either warm (below 50°C) or hot water (above 50°C), the LEX tank is connected to an electronic temperature control box to suit the application. This control box contains the accurate thermostatic controls necessary for safe operation.

COLD WATER PLUMBING – The minimum valving required prior to the heater is a stopcock, non-return valve, and a cold water expansion control valve set at 1200kPa. A line strainer is recommended.

HOT WATER PLUMBING – It is good practice to insulate heated pipe-work to reduce heat loss.

SOLAR PRE-HEATER – A tank can be connected to a bank of solar panels to pre-heat incoming cold water to a system.

Note: Glycol-filled systems are available as an option for frost-prone areas.

DIMENSIONS

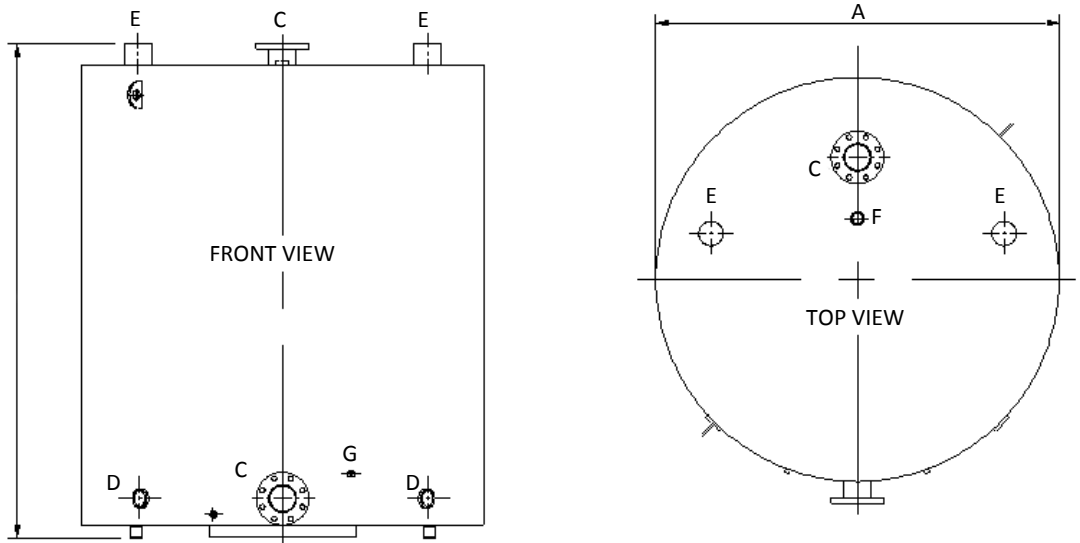

CLEARANCES

TOP = 150MM
FRONT = 150MM
SIDE = 50MM

SPECIFICATION

		LEX120	LEX200	LEX350	LEX500
Diameter of unit – A		1112	1362	1654	2016
Height of unit – B		2030	2030	2030	2030
Process Flow/Return Table E flange – C		Ø65	Ø80	Ø100	Ø100
Burner Flow/Return socket – D		65 BSP	80 BSP	80 BSP	100 BSP
Coil Flow/Return – E		Ø50 copper	Ø65 copper	Ø100 copper	Ø100 copper
Expansion Line BSP Socket - F		32 BSP socket	40 BSP socket	50 BSP socket	50 BSP socket
Thermostat Probe – G		15 ID x 120mm	15 ID x 120mm	15 ID x 120mm	15 ID x 120mm
Max Input (warm/hot)	kW	251/628	419/1047	732/1320	838/2095
Coil Peak Flow Rate (l/min)	warm	150	250	350	500
	hot	180	300	420	600
Storage Delivery (litres)	warm	141	220	335	510
	hot	989	1546	2345	3570
Coil Pressure Drop	kPa	33	33	33	33
Coil Surface Area	sq.m	12	20	28	40
Max Tank / Coil Working Pressure	kPa	400/1200	400/1200	400/1200	400/1200
Neutral Water Storage (litres)		1413	2209	3350	5100
Max No of Solar panels – if used for preheating	warm	8	10	16	20
	hot	14	24	36	60
weight (kg)	dry	525	1012	1486	2124
	wet	1939	3221	4836	7224

Tanks may be connected in parallel for greater versatility and output

NOTE: heater outputs calculated on a cold inlet temperature of 15°C

Care has been taken to ensure that all information is as accurate as possible at the time of publication.

However, specifications, methods and figures are subject to change without prior notice.

DISTRIBUTOR:



EDWARDS
commercial hot water

For more information

Call Sales 1300 132 949 (Australia only)

Call Service 1300 132 948 (Australia only)



Edwards Commercial Hot Water
39 Koornang Road, Scoresby, Victoria 3179
A division of Rheem Australia Pty Ltd ABN 21 098 823 511

Ph 61 (3) 9757 3333 – Fax 61 (3) 9757 3380
website: www.edwards.com.au
email: info@edwards.com.au

ETDS-LEX-VER1-251108