

# RAYPAK®

## Mechanical Heating and Hot Water



Green's General Foods, Glendenning.

### ALL THE BENEFITS OF THE ALL COPPER HEAT EXCHANGER

The use of direct fired pure copper finned heat exchangers has been well proven over time.

And in the past fifty years, the Raypak® range has developed the high input water heater even further.

The result? A system which not only resists the combined effects of corrosion and high temperature, but is extremely energy efficient.

In commercial applications, Raypak gives you significant cost savings. Raypak's compact, efficient heating design is the ideal way to heat large quantities of water for both hot water and hydronic applications.

Raypak copper tube gas water heaters are high quality, versatile and compact. Their thermal efficiency is an outstanding 82%, and because they have Hot Surface Ignition (HSI) or spark ignition they save on operating costs too.

Raypak's lightweight ceramic fibre refractory panels have an ingenious design which reduces heat losses – and this gives you further savings. Raypak's compact design makes it easy to install. And of course is covered by Rheem's service network, which is nothing less than the best in the country.



Bendigo Bank, South Melbourne

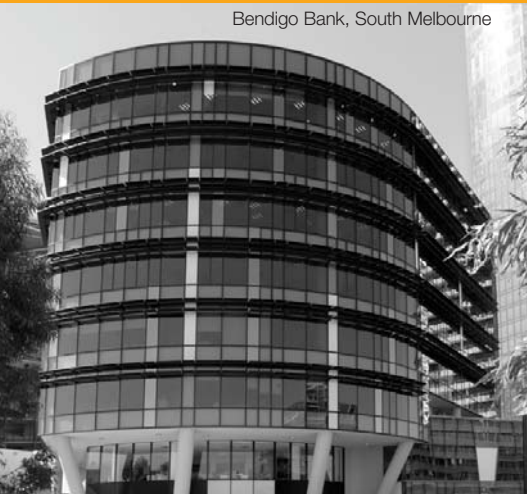

### WARRANTY PLAN

Rheem Customer Protection Plan.

5 Year Heat Exchanger. 1 Year Labour and Parts.<sup>1</sup>



HEATING AND HOT WATER

**Raypak®**

A RHEEM COMPANY



COMMERCIAL

rheem.com.au  
raypak.com.au

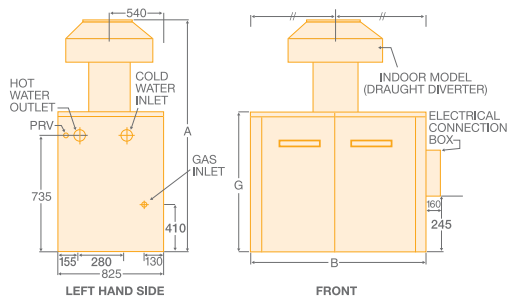

Models 992, 1182, 1292, 1412, 1722, 1922 (Indoor)

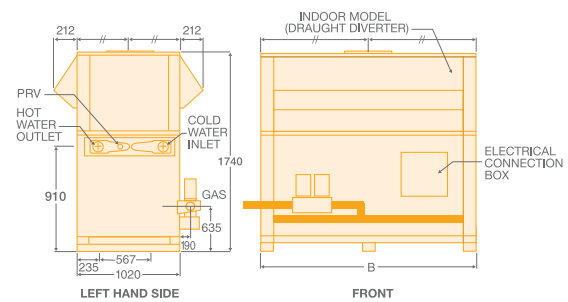

Models 2214, 2634, 3164, 3694, 4224 (Indoor)

**DIMENSIONS AND TECHNICAL DATA TABLE – INDOOR MODELS**

Model		992	1182	1292	1412	1722	1922	2214	2634	3164	3694	4224	
Natural	– Input	MJ/h	999	1,186	1,289	1,412	1,719	1,926	2,215	2636	3,165	3,692	4,224
	– Output	kW	225	265	285	315	380	430	505	600	720	840	960
Propane	– Input	MJ/h	933	1,090	1,186	1,296	1,581	1,772	2,150	2,530	3,035	3,540	4,045
	– Output	kW	205	240	265	290	350	395	480	560	675	790	900
Dimensions													
A	mm	1,810	1,915	1,915	1,990	2,060	2,130	-	-	-	-	-	
B	mm	1,330	1,510	1,615	1,740	2,070	2,270	1,550	1,780	2,060	2,350	2,640	
G	mm	860	860	860	860	930	930	-	-	-	-	-	
Flue Connection	mm	355	405	405	455	455	505	610	660	710	760	815	
Weight	kg	310	330	360	390	440	460	625	700	780	860	940	
Inlet/Outlet Connections		RC2½/65	RC2½/65	RC2½/65	RC2½/65	RC2½/65	RC2½/65	R3/80	R3/80	R3/80	R3/80	R3/80	
Gas Connection													
Natural – On / Off Models		R1½/40	R1½/40	R1½/40	R1½/40	R2/50	R2/50	R2/50	R2½/65	R2½/65	R3/80	R3/80	
Natural – Modulating Models		R1½/40	R1½/40	R1½/40	R1½/40	R2/50	R2/50	R2/50	R2½/65	R2½/65	R3/80	R3/80	
Propane – On / Off Models		R1¼/32	R1¼/32	R1¼/32	R1¼/32	R1½/40	R1½/40	R1½/40	R1½/40	R1½/40	R1½/40	R1½/40	
Propane – Modulating Models		R¾/20	R¾/20	R¾/20	R1/25	R1/25	R1½/40	R1½/40	R1½/40	R1½/40	R1½/40	R1½/40	
Relief Valve Connection													
On/Off Models		RC¾/20	RC¾/20	RC¾/20	RC¾/20	RC¾/20	RC¾/20	RC¾/20	RC¾/20	RC1/25	RC1/25	RC1/25	
Modulating Models		RC¾/20	RC¾/20	RC¾/20	RC¾/20	RC1/25	RC1/25	RC1¼/32	RC1¼/32	RC1½/40	RC1½/40	RC1½/40	
Electrical Rating 240V 50Hz	Watts	100	100	100	100	100	100	100	100	100	100	100	
	Amps	0.42	0.42	0.42	0.42	0.42	0.42	0.42	0.42	0.42	0.42	0.42	
Min. Buffer Tank Capacity	Litres	410	650	650	650	650	820	975	975	975	1,230	1,300	
Max. Storage Capacity	Litres	11,000	13,000	14,500	16,000	19,500	22,000	27,000	31,000	37,000	43,500	49,500	
Natural Gas													
Litres Recovery Per Hour @	30°C rise	6,450	7,597	8,170	9,030	10,893	12,327	14,477	17,200	20,640	24,080	27,520	
	40°C rise	4,838	5,698	6,128	6,773	8,170	9,245	10,858	12,900	15,480	18,060	20,640	
	50°C rise	3,870	4,558	4,902	5,418	6,536	7,396	8,686	10,320	12,384	14,448	16,512	
	60°C rise	3,225	3,798	4,085	4,515	5,447	6,163	7,238	8,600	10,320	12,040	13,760	
	65°C rise	2,977	3,506	3,771	4,168	5,028	5,689	6,682	7,939	9,526	11,114	12,702	
	70°C rise	2,764	3,256	3,501	3,870	4,669	5,283	6,204	7,372	8,846	10,320	11,794	
	75°C rise	2,580	3,039	3,268	3,612	4,357	4,931	5,791	6,880	8,256	9,632	11,008	
	80°C rise	2,419	2,849	3,064	3,386	4,085	4,623	5,429	6,450	7,740	9,030	10,320	
	85°C rise	2,276	2,681	2,884	3,187	3,845	4,351	5,109	6,071	7,285	8,499	9,713	
Flow Rate and Pressure Drop													
Max. Flow Rate													
Modulating (10°C rise)*	L/s	5.38	6.31	6.31	6.31	6.31	6.31	12.06	13.62	12.62	12.62	12.62	
Pressure Drop	kPa	29	44	46	46	55	58	48	49	50	54	57	
Max. Flow Rate													
On/Off (15°C rise)*	L/s	3.58	4.22	4.54	4.54	5.68	5.68	8.04	9.56	11.47	12.62	12.62	
Pressure Drop	kPa	12	18	24	24	50	58	20	28	38	54	57	
Min. Flow Rate													
(20°C rise)*	L/s	2.69	3.17	3.40	3.40	4.54	5.14	6.03	7.17	8.60	10.03	11.47	
Pressure Drop	kPa	7	11	14	14	30	39	12	17	23	30	42	

\*Guide only.

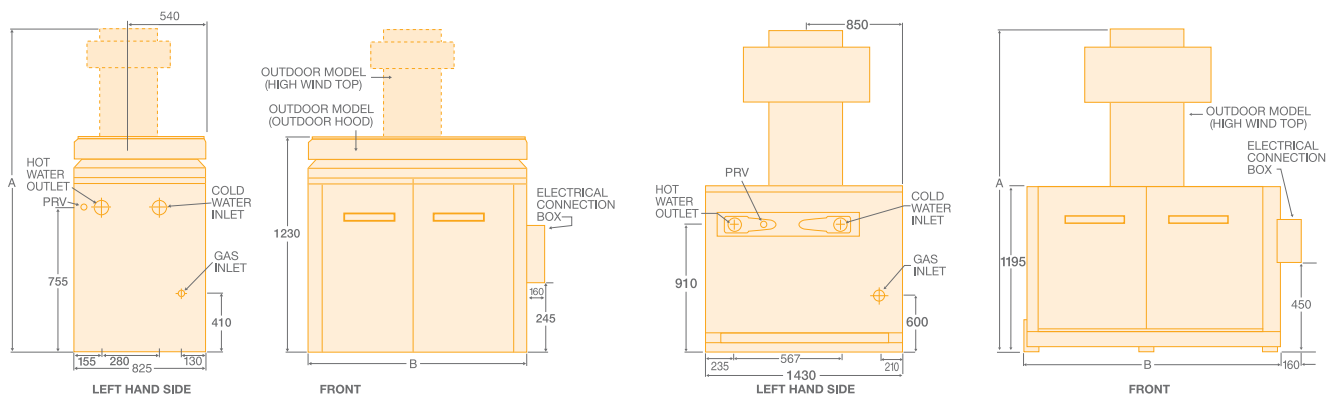

Models 972, 1142, 1242, 1362, 1662, 1852 (Outdoor)

Models 2004, 2404, 2804\*, 3304\*, 3804\* (Outdoor)

\*Two high wind tops per model

**DIMENSIONS AND TECHNICAL DATA TABLE – OUTDOOR MODELS**

Model		972	1142	1242	1362	1662	1852	2004	2404	2804	3304	3804	
Natural	– Input	MJ/h	976	1,142	1,242	1,357	1,657	1,854	2,004	2,404	2,804	3,304	3,804
	– Output	kW	220	255	275	300	370	410	445	530	625	740	845
Propane	– Input	MJ/h	933	1,090	1,186	1,296	1,581	1,772	1,595	2,530	2,278	2,659	3,038
	– Output	kW	205	240	265	290	350	395	354	560	508	595	675
Dimensions	A	mm	2,500	2,395	2,395	2,570	2,640	2,920	3,165	3,210	3,185	2,965	3,165
	B	mm	1,330	1,510	1,615	1,740	2,070	2,270	1,550	1,780	2,060	2,350	2,635
Weight	kg	360	385	410	440	510	520	650	730	810	890	970	
Inlet/Outlet Connections		RC2½/65	RC2½/65	RC2½/65	RC2½/65	RC2½/65	RC2½/65	R3/80	R3/80	R3/80	R3/80	R3/80	
Gas Connection													
Natural – On / Off Models			R1½/40	R1½/40	R1½/40	R1½/40	R2/50	R2/50	R2/50	R2½/65	R2½/65	R2½/65	R3/80
Natural – Modulating Models			R1½/40	R1½/40	R1½/40	R1½/40	R2/50	R2/50	R2/50	R2½/65	R2½/65	R3/80	R3/80
Propane – On / Off Models			R1¼/32	R1¼/32	R1¼/32	R1¼/32	R1½/40	R1½/40	R1½/40	R1½/40	R1½/40	R1½/40	R1½/40
Propane – Modulating Models			R¾/20	R¾/20	R¾/20	R1/25	R1/25	R1½/40	R1½/40	R1½/40	R1½/40	R1½/40	R1½/40
Relief Valve Connection													
On/Off models			RC¾/20	RC¾/20	RC¾/20	RC¾/20	RC¾/20	RC¾/20	RC¾/20	RC¾/20	RC1/25	RC1/25	RC1/25
Modulating models			RC¾/20	RC¾/20	RC¾/20	RC¾/20	RC1/25	RC1/25	RC1¼/32	RC1¼/32	RC1½/40	RC1½/40	RC1½/40
Electrical Rating 240V 50Hz	Watts		100	100	100	100	100	100	100	100	100	100	100
	Amps		0.42	0.42	0.42	0.42	0.42	0.42	0.42	0.42	0.42	0.42	0.42
Min. Buffer Tank Capacity	Litres	410	650	650	650	650	820	975	975	975	1,230	1,230	
Max. Storage Capacity	Litres	11,000	13,000	14,000	15,500	19,000	21,000	23,000	27,000	32,000	39,000	43,000	
Natural Gas													
Litres Recovery Per Hour at	30°C rise	6,307	7,310	7,883	8,600	10,607	11,753	12,757	15,194	17,917	21,214	24,224	
	40°C rise	4,730	5,483	5,913	6,450	7,955	8,815	9,568	11,395	13,438	15,910	18,168	
	50°C rise	3,784	4,386	4,730	5,160	6,364	7,052	7,654	9,116	10,750	12,728	14,534	
	60°C rise	3,153	3,655	3,942	4,300	5,303	5,877	6,378	7,597	8,958	10,607	12,112	
	65°C rise	2,911	3,374	3,639	3,969	4,895	5,425	5,888	7,012	8,269	9,791	11,180	
	70°C rise	2,703	3,133	3,379	3,686	4,546	5,037	5,467	6,512	7,679	9,092	10,382	
	75°C rise	2,523	2,924	3,153	3,440	4,243	4,701	5,103	6,077	7,167	8,485	9,689	
	80°C rise	2,365	2,741	2,956	3,225	3,978	4,408	4,784	5,698	6,719	7,955	9,084	
85°C rise	2,226	2,580	2,782	3,035	3,744	4,148	4,502	5,362	6,324	7,487	8,550		
Flow Rate and Pressure Drop													
Max. Flow Rate													
Modulating (10°C Rise)*		L/s	5.26	6.09	6.31	6.31	6.31	6.31	10.63	12.62	12.62	12.62	12.62
Pressure Drop		kPa	27	43	46	49	55	58	45	49	53	57	60
Max. Flow Rate													
On/Off (15°C Rise)*		L/s	3.50	4.06	4.38	4.78	5.68	5.68	7.09	8.44	9.95	11.79	12.62
Pressure Drop		kPa	12	18	23	30	50	58	18	28	35	53	57
Min. Flow Rate													
(20°C rise)*		L/s	2.63	3.05	3.28	3.58	4.42	4.90	5.32	6.33	7.47	8.84	10.09
Pressure Drop		kPa	7	10	12	16	27	21	12	17	21	30	42

\*Guide only.

**RAYPAK MODEL NUMBERS**

The following information should be supplied when ordering Raypak water heaters

B	0868	N	C	O	/	ID
Water	Approx	N = Natural Gas	Copper Heat	O = On/Off		ID = Indoor
Heater	Thermal Input*	P = Propane	Exchanger	M = Modulating		OD = Outdoor
						HWT = High Wind Top

\*Note: last digit designates series type

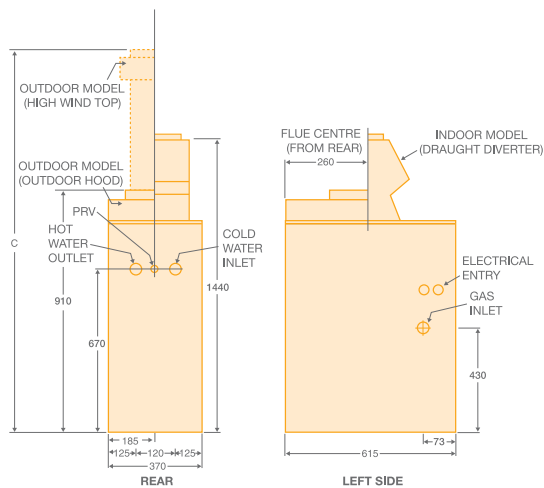

Model 147 (Indoor/Outdoor)

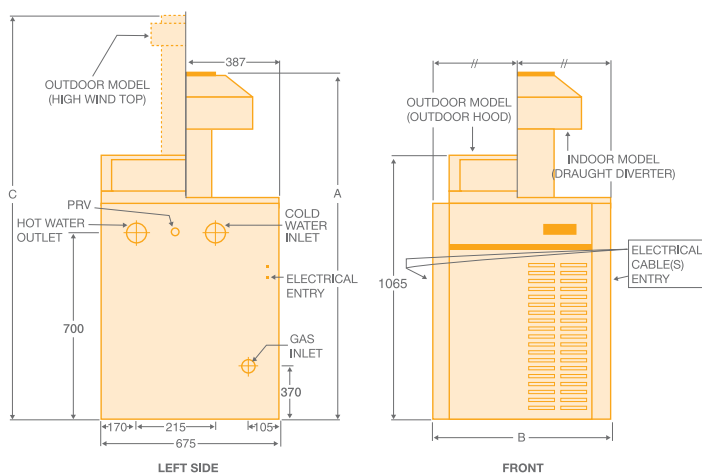

Models 200, 280, 350, 430, 507 (Indoor/Outdoor)

DIMENSIONS AND TECHNICAL DATA TABLE – INDOOR / OUTDOOR MODELS												
Model		147	200	280	350	430	507	538	658	768	868	
Natural	– Input	MJ/h	144	196	278	343	420	515	539	661	765	870
	– Output	kW	32	44	62	76	94	115	120	150	170	195
Propane	– Input	MJ/h	135	185	261	323	396	485	505	620	720	820
	– Output	kW	30	41	58	72	88	108	115	140	160	180
Dimensions												
A	mm	-	1,625	1,715	1,715	1,805	1,805	-	-	-	-	
B	mm	-	465	570	655	745	835	830	955	1,055	1,160	
C	mm	-	1,955	2,240	2,035	2,145	2,145	2,130	2,255	2,255	2,355	
Flue Connection	mm	150	175	205	225	255	255	255	305	305	355	
Weight	kg	71	91	93	103	107	115	195	200	250	260	
Inlet/Outlet Connections			RC1 <sup>1</sup> / <sub>4</sub> /32	RC1 <sup>1</sup> / <sub>2</sub> /40	RC1 <sup>1</sup> / <sub>2</sub> /40	RC1 <sup>1</sup> / <sub>2</sub> /40	RC1 <sup>1</sup> / <sub>2</sub> /40	RC1 <sup>1</sup> / <sub>2</sub> /40	RC2 <sup>1</sup> / <sub>2</sub> /65	RC2 <sup>1</sup> / <sub>2</sub> /65	RC2 <sup>1</sup> / <sub>2</sub> /65	
Gas Connection												
Natural – On / Off Models			RP <sup>3</sup> / <sub>4</sub> /20	RP <sup>3</sup> / <sub>4</sub> /20	RP <sup>3</sup> / <sub>4</sub> /20	RP <sup>3</sup> / <sub>4</sub> /20	RP <sup>3</sup> / <sub>4</sub> /20	R1/25	R1/25	R1 <sup>1</sup> / <sub>2</sub> /40	R1 <sup>1</sup> / <sub>2</sub> /40	R1 <sup>1</sup> / <sub>2</sub> /40
Natural – Modulating Models			not available	RP1/25	RP1/25	RP1/25	RP1/25	not available	R1/25	R1/25	R1 <sup>1</sup> / <sub>2</sub> /40	R1 <sup>1</sup> / <sub>2</sub> /40
Propane – On / Off Models			RP <sup>3</sup> / <sub>4</sub> /20	RP <sup>3</sup> / <sub>4</sub> /20	RP <sup>3</sup> / <sub>4</sub> /20	RP <sup>3</sup> / <sub>4</sub> /20	RP <sup>3</sup> / <sub>4</sub> /20	R1/25	R1/25	R1/25	R1 <sup>1</sup> / <sub>4</sub> /32	R1 <sup>1</sup> / <sub>4</sub> /32
Propane – Modulating Models			not available	RP <sup>3</sup> / <sub>4</sub> /20	RP <sup>3</sup> / <sub>4</sub> /20	RP <sup>3</sup> / <sub>4</sub> /20	RP <sup>3</sup> / <sub>4</sub> /20	not available	R <sup>3</sup> / <sub>4</sub> /20	R <sup>3</sup> / <sub>4</sub> /20	R <sup>3</sup> / <sub>4</sub> /20	R <sup>3</sup> / <sub>4</sub> /20
Relief Valve Connection												
On/Off Models			RC <sup>3</sup> / <sub>4</sub> /20	RC <sup>3</sup> / <sub>4</sub> /20	RC <sup>3</sup> / <sub>4</sub> /20	RC <sup>3</sup> / <sub>4</sub> /20	RC <sup>3</sup> / <sub>4</sub> /20	RC <sup>3</sup> / <sub>4</sub> /20	RC <sup>3</sup> / <sub>4</sub> /20	RC <sup>3</sup> / <sub>4</sub> /20	RC <sup>3</sup> / <sub>4</sub> /20	RC <sup>3</sup> / <sub>4</sub> /20
Modulating Models			N/A	RC <sup>3</sup> / <sub>4</sub> /20	RC <sup>3</sup> / <sub>4</sub> /20	RC <sup>3</sup> / <sub>4</sub> /20	RC <sup>3</sup> / <sub>4</sub> /20	N/A	RC <sup>3</sup> / <sub>4</sub> /20	RC <sup>3</sup> / <sub>4</sub> /20	RC <sup>3</sup> / <sub>4</sub> /20	RC <sup>3</sup> / <sub>4</sub> /20
Electrical Rating 240V 50Hz	Watts		50	50	50	50	50	50	50	50	50	
	Amps		0.21	0.21	0.21	0.21	0.21	0.21	0.21	0.21	0.21	
Min. Buffer Tank Capacity	Litres		325	325	325	325	325	325	325	325	325	
Max. Storage Capacity	Litres		1,650	2,000	3,000	4,000	4,800	5,700	6,000	7,500	8,500	10,000
Natural Gas												
Litres Recovery Per Hour at	30°C rise		917	1,250	1,769	2,187	2,683	3,297	3,440	4,300	4,873	5,590
	40°C rise		688	937	1,327	1,640	2,012	2,473	2,580	3,225	3,655	4,193
	50°C rise		550	750	1,061	1,312	1,610	1,978	2,064	2,580	2,924	3,354
	60°C rise		459	625	884	1,094	1,342	1,648	1,720	2,150	2,437	2,795
	65°C rise		423	577	816	1,010	1,238	1,522	1,588	1,985	2,249	2,580
	70°C rise		393	536	758	937	1,150	1,413	1,474	1,843	2,089	2,396
	75°C rise		-	500	708	875	1,073	-	1,376	1,720	1,949	2,236
	80°C rise		-	469	663	820	1,006	-	1,290	1,613	1,828	2,096
	85°C rise		-	441	624	772	947	-	1,214	1,518	1,720	1,973
Flow Rate and Pressure Drop												
Max. Flow Rate												
Modulating (10°C Rise)*		L/s	0.76	1.04	1.47	1.82	2.24	2.75	2.87	3.58	4.06	4.66
Pressure Drop		kPa	5	3	8	13	17	18	6	10	14	22
Max. Flow Rate												
On/Off (15°C Rise)*		L/s	0.51	0.69	0.98	1.22	1.49	1.83	1.91	2.39	2.71	3.11
Pressure Drop		kPa	3	3	4	6	8	9	3	4	6	8
Min. Flow Rate												
(20°C rise)*		L/s	0.38	0.52	0.74	0.91	1.12	1.37	1.43	1.79	2.03	2.33
Pressure Drop		kPa	3	3	3	3	4	5	3	3	4	5

\*Guide only.

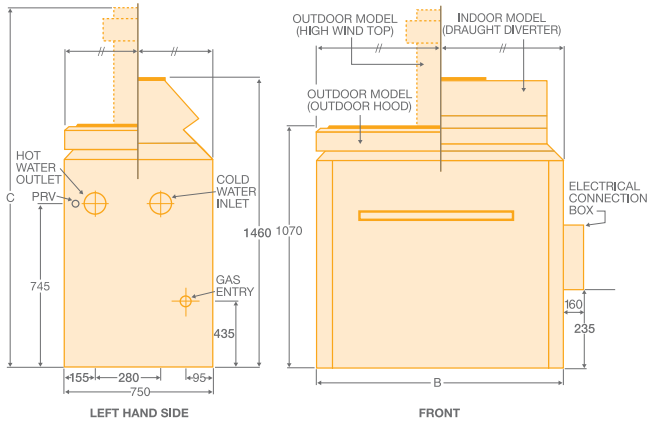

Models 538, 658, 768 & 868 (Indoor/Outdoor)

Temperature rise versus flow rate - Raypak water heaters Models 147 to 868 (Indoor /Outdoor) natural gas

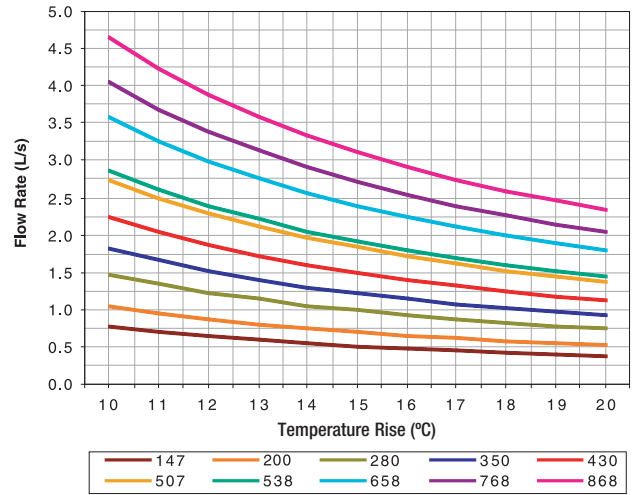

Single Mechanical Heating System

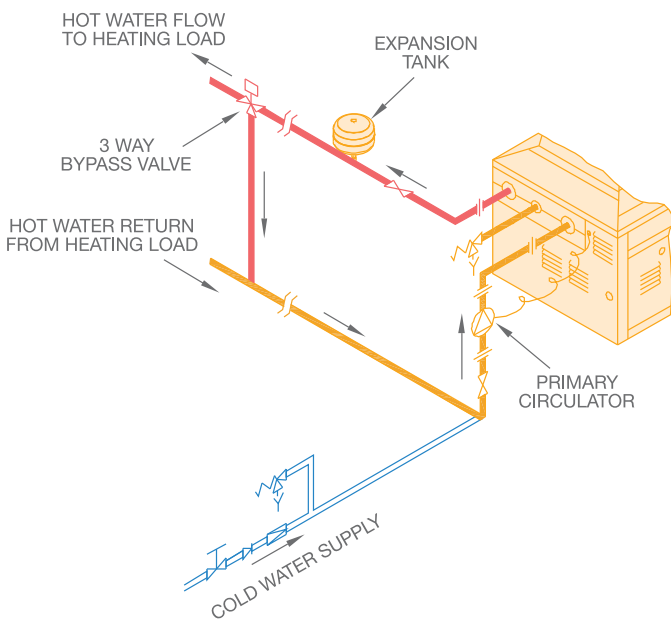

Temperature rise versus flow rate - Raypak water heaters Models 972 to 3804 (Outdoor) Natural Gas

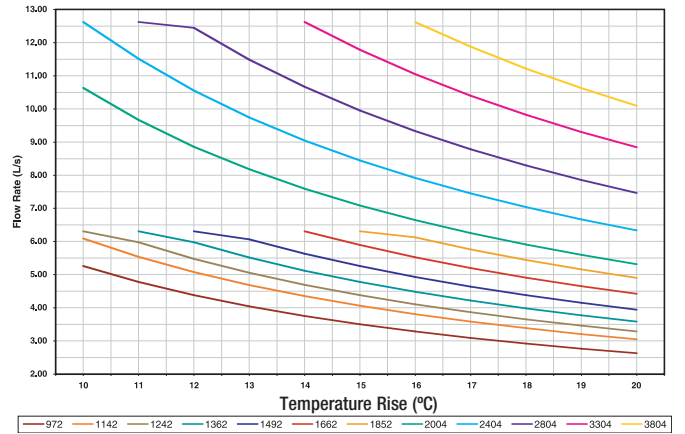

Temperature rise versus flow rate - Raypak water heaters Models 992 to 4224 (Indoor) Natural Gas

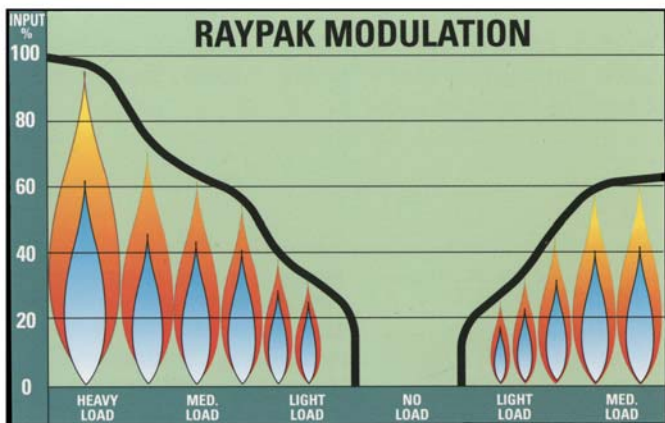
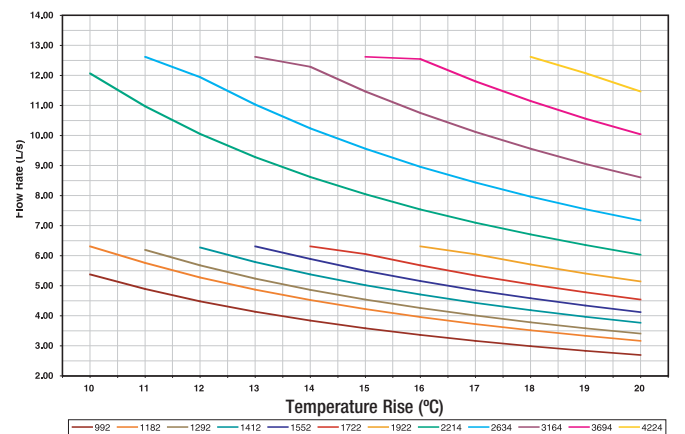

*CLEARANCES (mm) COMBUSTIBLES						NON COMBUSTIBLES				
Model	Back	Front	Left	Right	Ceiling	Back	Front	Left	Right	Ceiling
147	600	750	600	600	1,200	300	750	300	300	1,200
200 to 430	500	750	600	500	1,200	150	750	600	150	1,200
507 to 1922	600	750	600	600	1,200	150	750	600	600	1,200
2004 to 4224	600	1,200	600	600	1,200	300	1,200	600	600	1,200

\*Excludes flue terminal clearances. Refer to AS5601

### MINIMUM SUPPLY PRESSURE

System design and pump selection is critical when water heaters are connected to a low pressure water supply. Refer to the table below for minimum pressure requirements for Grundfos UPS series pumps. Minimum pressure requirements for TP series pumps depend on system characteristics and need to be calculated. Contact your pump supplier for details.

Pump	Model	Minimum Inlet Pressure Required (m) at Operating Temperature				
		75°C	80°C	85°C	90°C	95°C
UPS20-60B UP20-45N	147, 200, 280	0.5	0.5	0.5	3.0	5.0
UPS32-80B	350, 430, 507, 538, 658, 768, 868	0.5	0.5	0.5	3.0	5.0
UPS40-60/2B	768, 868, 972, 992, 1142, 1182, 1242, 1292	1.5	2.5	3.5	4.5	7.0
UPS50-120B	1362, 1412, 1492, 1552, 1662, 1722, 1852, 1922, 2004, 2214	4.0	5.0	6.0	7.0	9.0
UPS80-120B	2404, 2634, 2804, 3164, 3304, 3694, 3804, 4224	16.0	17.0	18.0	19.0	20.5



Joh Bailey Hair & Day Spa, Sydney.

### WATER SUPPLY AND RELIEF VALVE SETTINGS

Burner Type Models		On/Off All	Modulating	
			200-430	538-4224
Relief Valve Setting				
Potable Hot Water	kPa	850 (700) <sup>2</sup>	850 (700) <sup>2,3</sup>	850 (700) <sup>2,3</sup>
Mechanical Heating	kPa	-	310	415
Expansion Control Valve (ECV <sup>1</sup> ) Setting				
Potable Hot Water	kPa	700 (550) <sup>2</sup>	700 (550) <sup>2,3</sup>	700 (550) <sup>2,3</sup>
Mechanical Heating	kPa	-	-	-
Maximum Supply Pressure without ECV <sup>1</sup> fitted				
Potable Hot Water	kPa	680 (550) <sup>2</sup>	680 (550) <sup>2,3</sup>	680 (550) <sup>2,3</sup>
Mechanical Heating	kPa	-	240	330
with ECV <sup>1</sup> fitted				
Potable Hot Water	kPa	550 (450) <sup>2</sup>	550 (450) <sup>2,3</sup>	550 (450) <sup>2,3</sup>
Mechanical Heating	kPa	-	-	-

<sup>1</sup> Expansion Control Valve is not supplied with the water heater.

<sup>2</sup> Figures in brackets are to be used if a Raypak stainless steel storage tank is utilised in the system.

<sup>3</sup> An 850kPa relief valve can be fitted to modulating water heaters used in potable hot water applications.

### Double Domestic Hot Water System

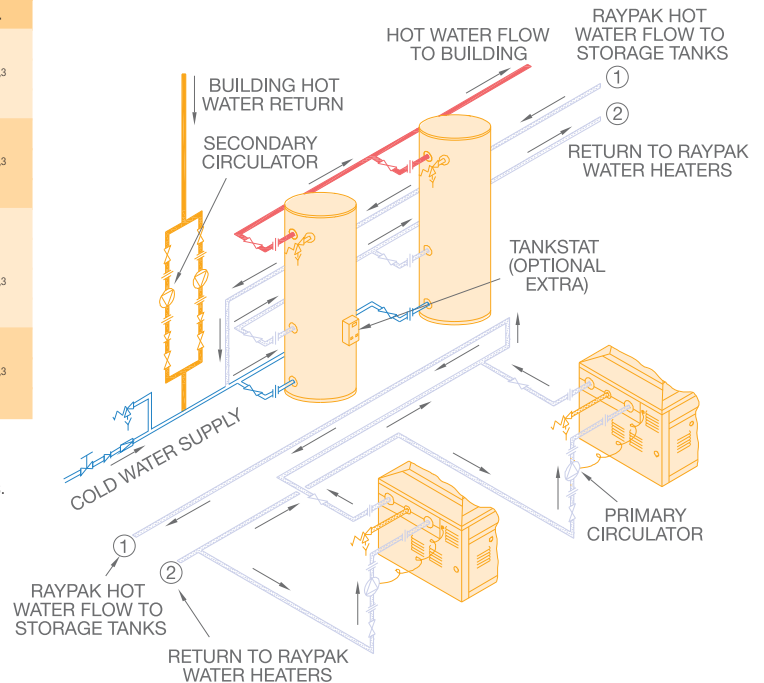

## ACCESSORIES FOR RAYPAK COMMERCIAL GAS WATER HEATERS

Accessories	Standard	Optional
Pump Run on Timer	All modulating	All On/Off
Tankstat	-	147 to 4224
Hot Surface Ignition (HSI)	147 to 430	-
Electronic Ignition	507 to 4224	-
Water Flow Switch	538 to 4224	-
Relay Run and Fault Status	507 to 4224	-
Temperature and/or Pressure Gauge (modulating burner models only)	-	197 to 4224
Temperature Gauge (on/off models only)	-	147 to 4224
High Wind Terminal (outdoor installations only)	1852 to 4224	147 to 1662
Rear Water Connections	147	-
Left Hand Water and Gas Connections	200 to 4224	-
Right Hand Water Connections	-	200 to 507
Right Hand Water and Gas Connections	-	538 to 4224
Audible Alarm	-	538 to 4224
Ambient Air Sensor (modulating burner models only)	-	538 to 4224

## RHEEM COMMERCIAL STORAGE TANK.

Rheem commercial storage tanks offer the perfect combination of performance and long life flexibility. They connect to the mains pressure water supply with 50mm water connections for maximum flow and are suitable for use in combination with a Raypak water heater as a buffer tank, for solar preheat storage or as additional storage for a Rheem hot water system.

The storage tanks can be installed utilising the Rheem Equa-Flow principle, in a bank of up to eight units to provide 3280 litres of storage or in multiple banks if more storage is required.

And they are covered by the Rheem 5 year customer protection plan.<sup>1</sup>

### Storage tank 610 340 & 610 430

GAS PRESSURE		147-430	507-4224
Natural –	Minimum	kPa 0.95	1.10
	Test Point	kPa 0.77	0.92
	Maximum	kPa 3.50	4.00
Propane –	Minimum	kPa 2.75	2.75
	Test Point	kPa 2.75	2.75
	Maximum	kPa 3.50	4.00

THERMOSTAT SETTINGS		
Modulating	Maximum	°C 95
	Factory set	°C 78
	Minimum	°C 44
On/Off	Maximum	°C 80
	Factory set	°C 50
	Minimum	°C 44

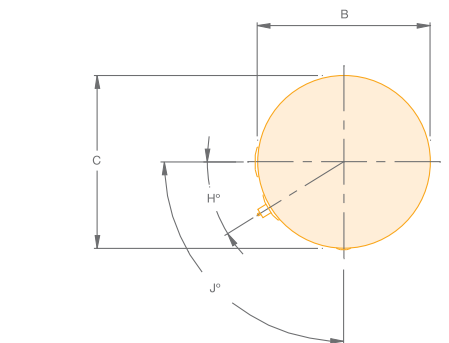
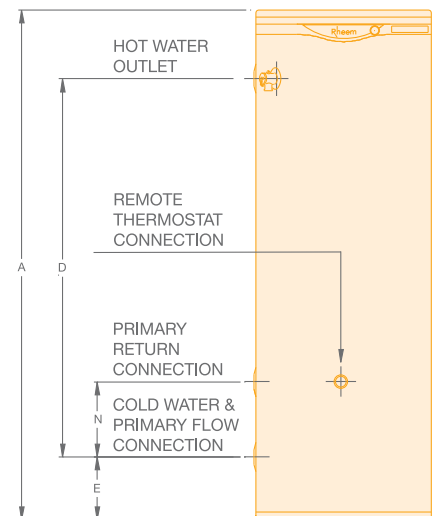

STORAGE TANK DIMENSIONS AND TECHNICAL DATA TABLE				
Model number			610 340	610 430
Storage capacity		Litres	325	410
Dimensions	A	mm	1,640	1,835
	B	mm	640	685
	C	mm	640	685
	D	mm	1,298	1,482
	E	mm	115	108
	H	Degrees	32°	30°
	J	Degrees	90°	84°
	N	mm	290	273
Weight Empty		kg	87	111
Inlet/Outlet Connections			RP2/50	RP2/50
T&PR Valve Connection			RP <sup>3</sup> / <sub>4</sub> /20	RP <sup>3</sup> / <sub>4</sub> /20
Remote Thermostat Connection			RP <sup>1</sup> / <sub>2</sub> /15	RP <sup>1</sup> / <sub>2</sub> /15
T&PR Valve Setting		kPa	1,000	1,000
Expansion Control Valve (ECV)* Setting		kPa	850	850
Maximum Water Supply Pressure		kPa	800	800
		kPa	680	680
Maximum Stored Water Temperature		°C	82	82
Manifold – Min Centre to Centre		mm	890	935

\*Expansion control valve is not supplied with the water heater.



Radisson Plaza Hotel, Sydney.



#### SPECIAL FEATURES.

- Hot Surface Ignition (HSI).
- Compact design, suitable for low ceiling heights.
- Efficient all copper finned heat exchanger.
- Ceramic fibre refractory panel insulation.
- Flame modulation to cater for low load requirements.
- Slide out heat exchanger for easy servicing.
- Flow switches and temperature and pressure gauges available.
- All Raypak models are available with On/Off burners and all, except the 147 and 507 models, are available with modulating burners.
- Raypak commercial water heaters are suitable for mechanical heating applications, installed as either closed or vented systems.
- Additional storage tanks offer mains pressure performance.
- The wide range with modulating gas control, which matches fuel input down to 20% of full fire, makes Raypak the ideal choice.
- Fast automatic response to temperature changes is provided by the optional outdoor Ambient Air Sensor controller.
- Models from 538 up to 4224 can be connected to a building management system for monitoring.
- The entire range of Raypak commercial water heaters is completely suited for domestic hot water loads, giving you continuous hot water.
- They're also an ideal heat source where system water temperatures of below 35°C are required.
- The On/Off type water heaters can operate as low as 41°C without any condensation or sooting.

Rheem are continually working to refine and improve water heating solutions. Our national network of Technical Sales Specialist and Managers can provide you with free on-site assistance in:

- Specifying, sizing and recommendations
- An audit of existing equipment for solar replacement
- A Rheem design proposal
- After sales training and service

For more information on the Rheem and Raypak Commercial range call 132 552 or visit [rheem.com.au](http://rheem.com.au)

Australia  
Sales 132 552  
Service 131 031

New Zealand  
Sales 0800 657 336  
Service 0800 657 335  
[rheemnz.co.nz](http://rheemnz.co.nz)

1. Conditions apply. Materials and specifications are subject to change without notice.  
\*Registered Trademark of Rheem Australia Pty. Ltd. Date of Printing July 2009.



Yarra's Edge Apartments, Docklands Melbourne

HEATING AND HOT WATER

**Raypak**<sup>®</sup>

A RHEEM COMPANY

[rheem.com.au](http://rheem.com.au)  
[raypak.com.au](http://raypak.com.au)



COMMERCIAL